

DmixTM



**Bi-directional Rigid frontal dumper, hydrostatic,
6 cu.m heaped, 10000 kgs capacity**



Dmix D-10



TECHNICAL SPECIFICATIONS

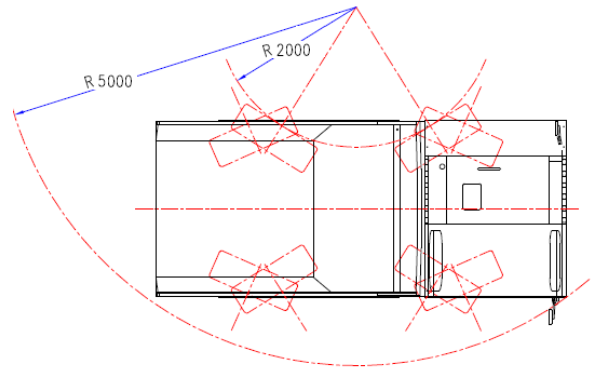

DIESEL ENGINE	Stage IIIA / Tier 3
Model :	PERKINS series 1,104
Type :	Turbo
Total displacement, no Cylinders :	4,400cc - 4 in line
Injection :	mechanical control with direct injection
Cooling :	air water, dry air fi lter
Maximum power :	83 kW (113 Hp)
Adj. power :	83 kW (2,200 rpm)
Maximum torque :	418 Nm a 1,400 rpm
Alternator :	12 V - 65 A

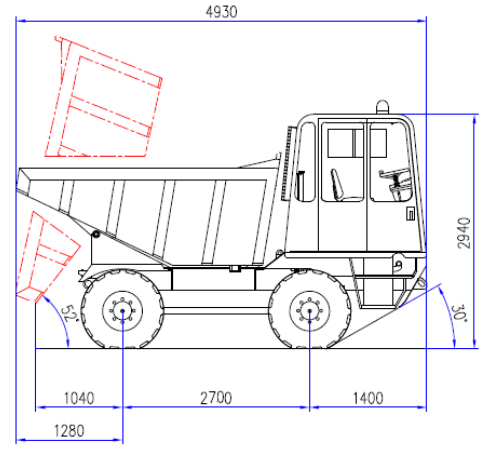

ELECTRIC SYSTEM

Battery: 12 V - 132 Ah (600 A)
Road light system, rear working lights.
COBO Made in Italy

T-WAY SISTEM

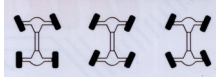

4X4 FOUR-WHEEL DRIVE

Hydrostatic "automotive" transmission with variable displacement pump and variable displacement hydraulic motor with electro-hydraulic control, and reverse gear control on the steering wheel. Mechanical gearbox for "working speed" and "road transfer" speed, with mechanical control.

BRAKES

Brake pump Brand: SAFIM made in Italy
Internal oil-bath disc service and emergency brakes acting on the 4 wheels, activation with pump on independent dual circuit. Negative type parking brake, with internal oil-bath discs on the front axle and electro-hydraulically controlled release.

SPEED

Working speed from 0 to 12 km/h
Road transfer from 0 to 25 km/h

STEERING

Brand Bondioli e Pavesi or MS Hydraulic
Assisted by means of power steering on 4 steering wheels; steering selection device for: 2 steering wheels, 4 steering wheels - crab steering.

AXLES AND WHEELS

Brand Dana Spicer Made in Italy
Front load-bearing, oscillating ($\pm 6^\circ$) and steering with planetary reduction gears on the wheel hubs.
Rear load-bearing and steering with planetary reduction gears on the wheel hubs and directly fl angled gearbox.
Front and rear tyres: 18-19.5 16 PR
Brand: Mitas or BKT

EQUIPMENT HYDRAULIC SYSTEM

Gear pump
Max. flow rate:45 litres/min.
Maximum pressure: 230 bar
2 - elements distributor.
Aluminium heat exchanger for hydraulic oil cooling.
Pressurised closed-circuit intake with oil fi lter replaceable from the outside.
Brand Bondioli e Pavesi made in Italy

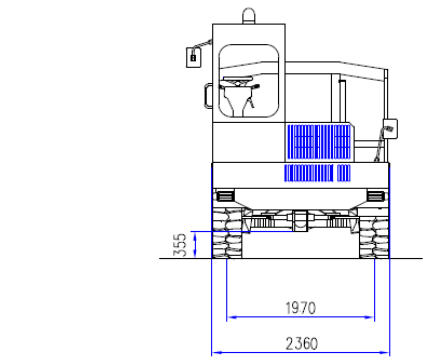

CAB

Cabin with glass on front, rear and left side accordance with ROPS FOPS.
180° pivoting driving post. Anatomic seat with flexible suspension and height adjustment, seat belts.
Driving and equipment controls with ergonomic arrangement.

SERVICE REFILL CAPACITIES

Fuel tank:.....90 litres
Total hydraulic system capacity:180 litres
Engine oil:9 kg

DUMP BODY

Heavy duty rock type
Dump body with tilting by means of 2 double-acting jacks.
Struck capacity 5,000 litres
Heaped capacity 6,000 litres

WEIGHTS

Operating weight5,590 kg
Max gross weight:15,590 kg
load-carrying capacity:10,000 kg



The picture can shows optional accessories. Technical specifications and dimensions are only for information and not binding for the producer. In accordance with our policy of continual improvements, we reserve the right to modify such specifications without notice.